

---

# Principles and Use of Ball Bearings

Course No: M03-019

Credit: 3 PDH

---

Robert P. Tata, P.E.

---



Continuing Education and Development, Inc.  
22 Stonewall Court  
Woodcliff Lake, NJ 07677

P: (877) 322-5800  
[info@cedengineering.com](mailto:info@cedengineering.com)

---

# Principles and Use of Ball Bearings

Copyright 2012  
Robert P. Tata  
All Rights Reserved

## Table of Contents

<u>Subject</u>	<u>Page</u>
Purpose	2
Description	2
Theory of Operation	2
Manufacture	4
Types	4
Selection	12
Specialty Ball Bearings	16
Internal Clearance	21
Shaft and Housing Fits	24
Lubrication	24
Application	26

## Ball Bearings

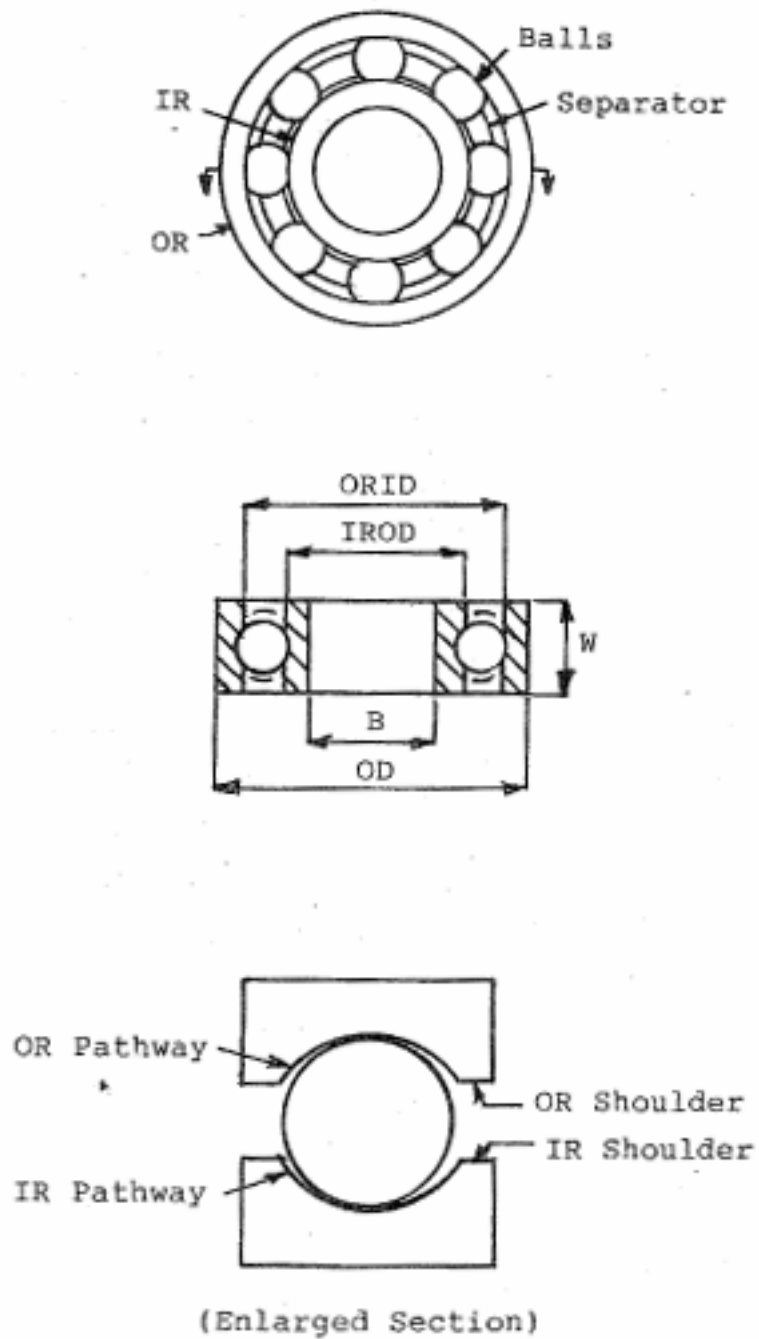
**Purpose:** Ball Bearings are used primarily to support rotating shafts in mechanical equipment. They can be found in the smallest electric motors to the largest pieces of industrial equipment. They are of simple design and can be precision manufactured in mass production quantities. They can support heavy loads over a wide speed range and do it virtually friction free. They come in many different sizes and shapes, are relatively inexpensive, and require little or no maintenance. They have predictable design lives and operating characteristics and are truly a valuable asset to the rotating equipment industry.

**Description:** A ball bearing consists of an inner ring (IR), an outer ring (OR), a complement of balls, and a separator. See Figure 1. The outer diameter of the inner ring (IROD) and the inner diameter of the outer ring (ORID) have a groove in which the balls roll. The groove is commonly called the pathway. The raised surface on each side of the pathway is called the shoulder. The balls are held equally spaced around the annulus of the bearing by the separator. The basic dimensions of the bearing are the bore (B), outside diameter (OD), and the width (W). The radius of curvature of the pathway must be closely controlled in relation to the ball diameter in order for the bearing to operate satisfactorily. If the radius of curvature is too close to the ball diameter, the bearing will operate with a high amount of friction. If the radius of curvature is too large in relation to the ball diameter, the bearing will operate under a high stress level. Both conditions will contribute to premature bearing failure. The radius of curvature of inner ring and outer rings is normally held to 52 - 53% of ball diameter. See Figure 1.

**Theory of Operation:** In most applications, there are two ball bearings supporting a rotating shaft. The inner ring is a press fit on the shaft while the outer ring is a close push fit into the housing. The shaft and inner ring rotate together while the outer ring remains stationary or undergoes slight rotational creep in the housing. The separator and ball complement rotate around at about half the speed of the inner ring. The balls rotate around their own axis about twice the speed of the inner ring. Loads, or forces, are imposed on the bearings by the equipment that is driving or being driven by the shaft. The loads can be separated into a radial component that acts 90 degrees to the shaft and a thrust component that acts along the centerline of the shaft. Normally the radial component is reacted by just a few balls in the bearing while the thrust component is supported by all the balls in the bearing.

Figure 1

Ball Bearing Terminology



Assume that the radial load is acting in the downward direction. The balls at the top of the bearing are under little or no load. As they rotate to the bottom of the bearing, they are compressed between the rings. As they rotate back to the top, the compressed metal expands back to its original state. This constant compression and expansion of metal after many revolutions of the bearing leads to fatigue failure. The failure usually occurs as a small pit or spall in the inner ring. The bearing then begins to make noise and is replaced. Figure 2 shows how to calculate individual ball loads in a bearing.

Manufacture: Ball bearings are manufactured to a very high precision level in high volume quantities. In some cases, lines are completely automated starting from the raw material phase to the finished product. Great care has to be taken to keep all parts clean and free of rust. The material used is a high carbon, high chromium alloy steel that is freer of voids and impurities than standard grades. High carbon content makes it heat treatable to high hardness levels throughout the part. High chromium levels impart high temperature strength. Inner and outer rings are processed as follows:

- a) Rings are machined from special sized steel tubing.
- b) They are thru-hardened in heat treat furnaces.
- c) Every surface is fine ground to exacting tolerances.
- d) Pathways are honed to even finer surface finishes.

Balls are processed as follows:

- a) They are cold headed to a spherical shape from drawn bar.
- b) They are soft ground.
- c) They are thru-hardened in heat treat furnaces.
- d) They are hard ground.
- e) They are lapped to a mirror-like finish.

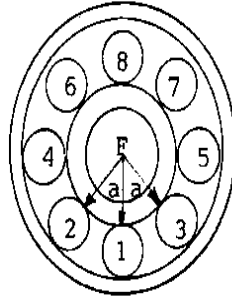
Assembly is accomplished as follows:

- a) The inner ring is placed off-center inside the outer ring.
- b) The balls are put inside the crescent shaped space.
- c) The inner ring is centered and the balls are evenly spaced.
- d) The separator is installed. See Figure 3.

Types: Heretofore the type of ball bearing discussed has been the single row radial. Radial bearings are used to support loads that are predominantly radial or perpendicular to the bearing axis of rotation. Another type of radial bearing is the maximum capacity bearing. It has a loading groove cut across one shoulder of each ring allowing more balls to be assembled into the bearing.

Figure 2

Ball Bearing Theory



Exaggerated View Showing Effect of  
Radial Load on Ball Force Distribution

With radial load acting down on inner ring:

- 1) Ball number 1 is the heaviest loaded.
- 2) Balls 2&3 are the next heaviest loaded.
- 3) Balls 4,5,6,7,&8 are unloaded.

$$\text{Radial Load} = F_1(1+2\cos^{5/2}a+2\cos^{5/2}2a+\text{etc})$$
$$\text{Load on Balls 2\&3} = F_1\cos^{3/2}a$$

Using the above equations with radial load = 570lb:

(570lb = rated load of above bearing)

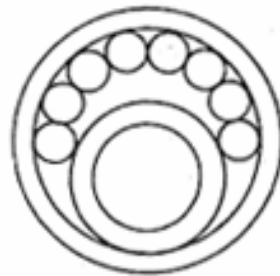
- 1) Load on ball 1 = 310lb
- 2) Load on ball 2&3=184lb each

Figure 3

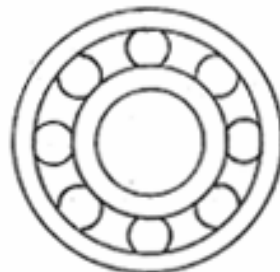
Conrad Assembly



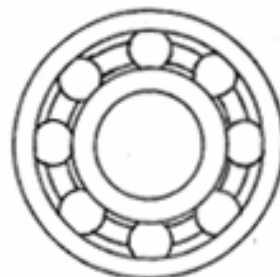
The IR is placed off-center inside the OR.



The balls are placed in the open space.



The IR is centered and the balls spaced.



The separator is installed.



Bearing capacities can be increased approximately 10% to 35% with the maximum capacity design. Because the loading grooves cut into the ball pathway shoulders, thrust capacity is limited. Moderate thrust loads can be taken if accompanied by substantial radial loading. See Figure 4.

Single row radial ball bearings can be furnished with shields, seals, and snap rings. Shields and seals are closures which are used to retain lubricant and prevent contaminant entry. A shield is a thin metal disc that is crimped into a groove in the outer ring ID. It can cover either one or both open ends of a bearing. It rides close to but does not contact a groove in the inner ring OD. Shields can also be used to control the flow of lubricant supplied to the bearing from an adjacent housing.

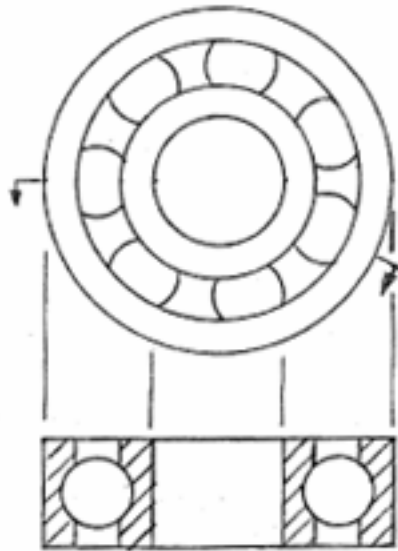
Seals are constructed of a thin layer of rubber covering a thin metal stiffening disc. They snap into the outer ring groove and have a rubber lip that firmly contacts the inner ring notch. The lip is intricately designed to seal in lubricants and seal out contaminants. Some seals have two or three lips for even greater protection to the bearing. Bearings can be furnished greased and double sealed and run maintenance free for their entire design lives. Snap rings are used for retention of bearings in housings. See Figure 5.

Another type of single row ball bearing is the angular contact bearing. An angular contact bearing is not a radial bearing; instead, it has a contact line that is at an angle to that of a radial bearing. The contact angle can be from 15 to 35 degrees. One whole shoulder of the outer ring is removed allowing a full complement of balls to be assembled into the bearing. The contact line is directed away from the side of the outer ring that has the shoulder removed. Angular contact bearings can support higher thrust loads than other types of single row bearings. In pairs with back-to-back mounting, they provide good axial rigidity. In pairs with face-to-face mounting, they can accommodate high misalignment. Tandem mounting provides even better thrust capability than a single bearing. See Figure 6.

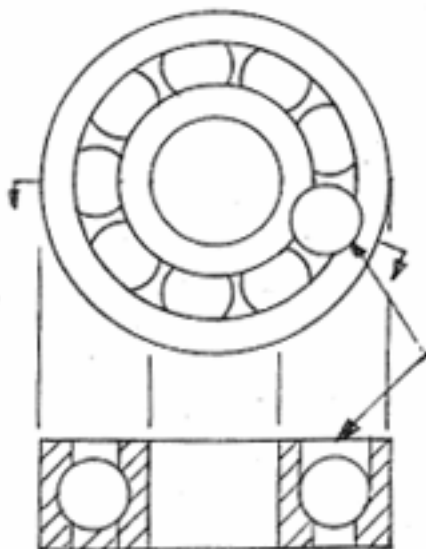
Double row ball bearings have extra wide inner and outer rings containing two separate side-by-side ball rows. They operate like two adjacent angular contact ball bearings but in a narrower space. They can withstand a combination of high radial and thrust loads. They can be furnished with the contact angles internally divergent or internally convergent. Internally divergent designs provide resistance to shaft bending while internally convergent designs are used where shaft misalignment is expected. See Figure 7.

Figure 4

Ball Bearing Types



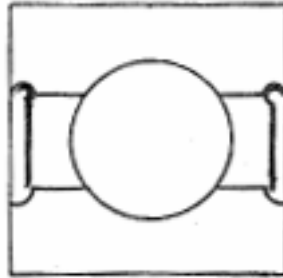
Radial Ball Bearing  
7-13/32 in Balls  
Capacity = 1200 lb



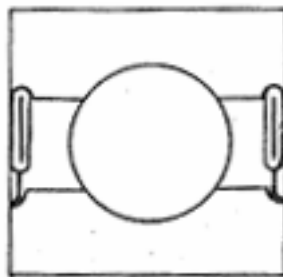
Maximum Capacity Version  
of Above Bearing  
9-13/32 in Balls  
Capacity = 1440 lb

Figure 5

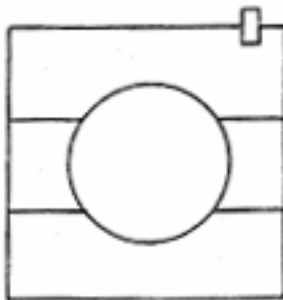
Ball Bearing Attachments



Ball Bearing  
With  
Non-Contacting Shields



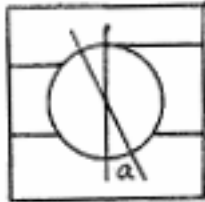
Ball Bearing  
With  
Contacting Seals



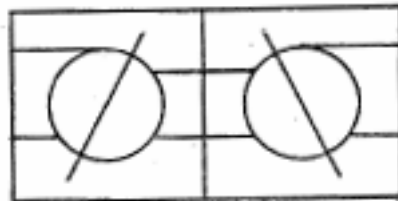
Ball Bearing  
With  
Snap Ring

Figure 6

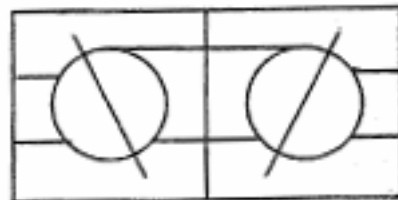
Ball Bearing Types



Angular Contact (a)  
Ball Bearing



Back-to-Back  
Mounting



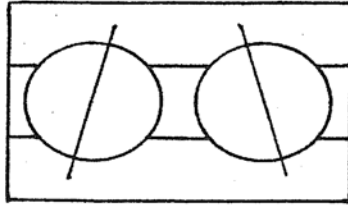
Face-to-Face  
Mounting



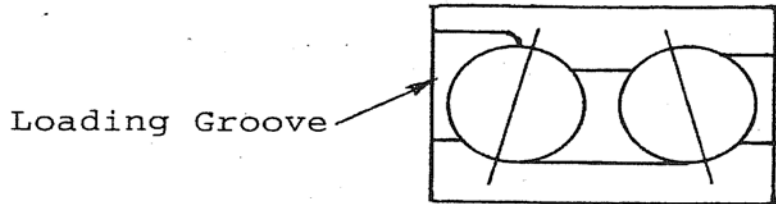
Tandem  
Mounting

Figure 7

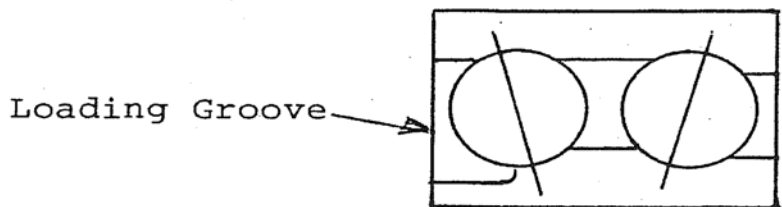
Ball Bearing Types



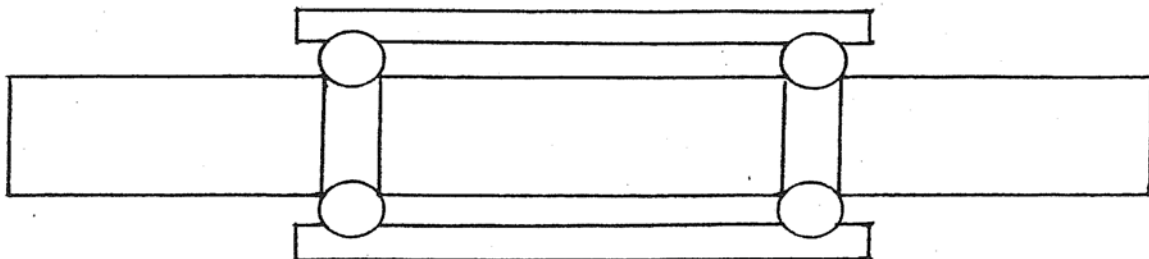
Double Row  
Internally Divergent



Internally Divergent  
Larger Sizes



Double Row  
Internally Convergent



Integral Shaft  
Double Row Ball Bearing

Most bearings come in three different series: extra light, light, and medium. The lighter series provide design compactness while the heavier series provide good load carrying capability. See Figure 8. All the series come in metric as well as inch sizes. See Figure 9.

Selection: Bearings are selected by the hours of life required under the conditions imposed by the application. The formula below is one used to calculate bearing life. Bearing life is expressed in B10 hours which are the hours that 90% of all bearings are expected to meet. The remaining 10% may not meet the calculated value.

$$\text{Life} = 3000 \times (C / (R \times F))^E \times (500 / S)$$

C is the capacity of the bearing in pounds and is found in bearing catalogs. R is the radial load in pounds. F is a factor that is used if a thrust load is present and is also found in catalogs. E is the exponent 10/3 or 3.333. S is the speed in rpm. The following is a sample problem:

A shaft supported by two identical single row radial ball bearings has a gear at the center driving a tool at one end at 2000 rpm. One bearing supports a 100# radial load while the other supports a 100# radial load and a 100# thrust load. The capacity of each bearing is 570#. The calculated life of each bearing using the above formula is as follows:

$$L = 3000(570 / (100 \times 1.00))^{3.333} \times (500 / 2000) = 246,674 \text{ B10 hr (R=100\#, T=000\#)}$$

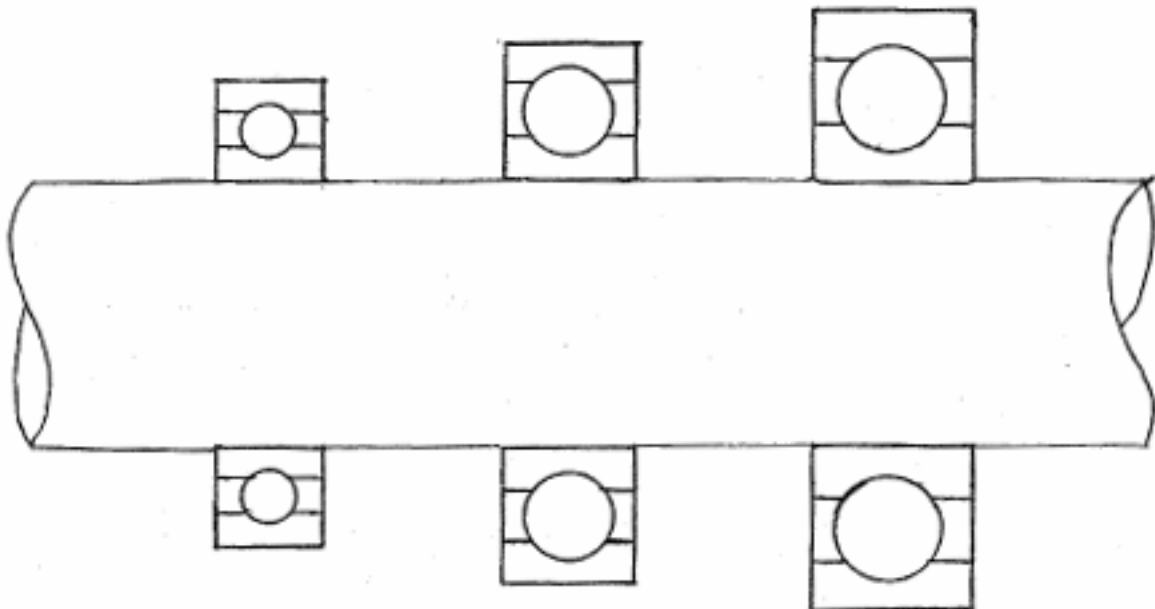
$$L = 3000(570 / (100 \times 1.72))^{3.333} \times (500 / 2000) = 40,533 \text{ B10 hr (R=100\#, T=100\#)}$$

The B10 life of the first bearing is very high. A smaller bearing could be used; however, it is common to use the same bearing at each end of a shaft for reasons of standardization and also to simplify shaft and housing design and manufacture. The B10 life of the second bearing represents 4.6 years of continuous operation.

Suppose the machine tool in the previous example experienced severe vibration and corrective action had to be taken. One approach in solving the problem is to preload the bearings. Preloading is accomplished by applying a thrust load to one bearing and having it reacted by the other on the same shaft. This has the effect of stiffening the bearings and making the shaft less prone to vibration. Assume that, after preloading, the thrust increases from 0# to 100# on the first bearing and from 100# to 200# on the second.

Figure 8

Ball Bearing Series



**Extra Light Series**

Bore  
35 mm

OD  
62 mm

Width  
14 mm

Balls  
11-5/16 in

Capacity  
950 lb

**Light Series**

Bore  
35 mm

OD  
72 mm

Width  
17 mm

Balls  
9-15/32 in

Capacity  
1900 lb

**Medium Series**

Bore  
35 mm

OD  
80 mm

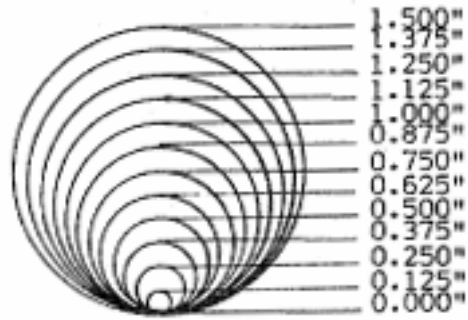
Width  
21 mm

Balls  
8-9/16 in

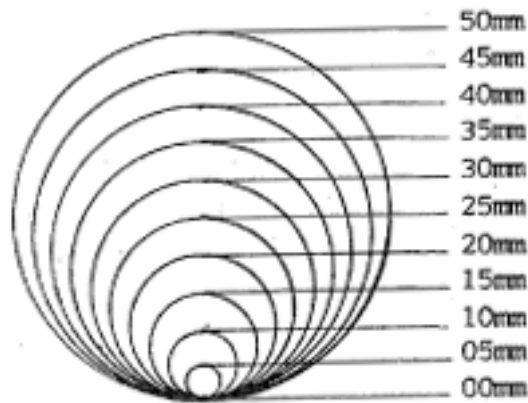
Capacity  
2400 lb

Figure 9

Ball Bearing Bore Sizes



Relative Bore Sizes  
Inch Series  
Full Scale



Relative Bore Sizes  
Metric Series  
Full Scale



The radial load remains the same. Using the existing radial bearings, the new calculated lives are as follows:

$$L=3000(570/(100 \times 1.72))^{3.333} \times (500/2000)=40,534 \text{ B10 hr (R=100\#, T=100\#)}$$

$$L=3000(570/(100 \times 2.84))^{3.333} \times (500/2000)= 7,631 \text{ B10 hr (R=100\#, T=200\#)}$$

It can be seen that the lives of the bearings have decreased significantly from the 246,670 and 40,533 numbers obtained before preloading. Now, let us repeat the above calculations using angular contact bearings with the same basic dimensions:

$$L=3000(475/(100 \times 1.03))^{3.333} \times (500/2000)=121,816 \text{ B10 hr (R=100\#, T=100\#)}$$

$$L=3000(475/(100 \times 1.69))^{3.333} \times (500/2000)= 23,420 \text{ B10 hr (R=100\#, T=200\#)}$$

The use of angular contact ball bearings, as seen from the above calculations, has increased predicted life by more than threefold. This exercise has shown how angular contact ball bearings can improve design life when higher thrust loads are present.

Another possible solution to the tool vibration would be to use the original radial bearing in the first position and replace the radial bearing in the second position with a double row ball bearing. The double row ball bearing would be the same size as the original bearing except that it would be 45% wider. The additional width could easily be accommodated by a minor rework to the shaft and housing. The double ball bearing would be internally divergent which would add rigidity to the shaft and prevent tool vibration. It would also eliminate the need for preloading the two bearings as was investigated in the previous analysis. The life of the bearing in position 1 would remain at a very high level. The life of the double row ball bearing in position 2 would be as follows:

$$L=3000(800/(100 \times 2.08))^{3.333} \times (500/2000)=66,558 \text{ B10 hr (R=100\#, T=100\#)}$$

The life of the double row ball bearing in position 2 is a 64% increase over the original radial ball bearing. In summary, because of the inherent design of the double row ball bearing, it stiffened the shaft to prevent machine tool vibration and increased the life of the bearing in position 2. The design no longer needs special devices to preload the two bearings which can be a bigger task than fitting in a slightly wider bearing in the position.

**Specialty Ball Bearings:** Integral shaft ball bearings as previously seen in Figure 7 are an excellent design tool used in everything from lawn mowers to washing machines. Inner pathways are ground directly on a hardened steel shaft permitting use of a larger shaft for increased strength and rigidity. The two ball rows are spread apart providing increased stability and resistance to moment loading. A variety of different seals can be used at each end to exclude contaminants and contain a large amount of lubricant that is placed between the spread apart ball rows. The shaft extensions can be furnished to various configurations for mounting a wide variety of mechanical components. See Figure 10.

Millions of integral shaft ball bearings are being used as fan and waterpump bearings on automobile engines. The water impeller is press fit on the back shaft extension and the engine cooling fan and waterpump drive pulley are pressed onto the front extension. Because of the very stringent demands on the bearing for this application, state of the art seals and lubricant are being used. Figure 11 shows a traditional integral shaft bearing in an automobile engine waterpump and a more recent design utilizing a close coupled bearing with a stepped shaft.

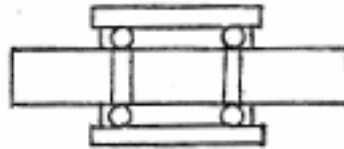
Two piece inner ring bearings combine the advantages of the maximum capacity and angular contact types. Because of the removable split inner ring, a maximum capacity ball complement can be used enabling the bearing to withstand high thrust loads from either direction. Special inner ring grinding can tighten the internal clearance of the bearing making it a more rigid support for reducing shaft bending. See Figure 12.

Cam follower bearings have thick outer rings to provide for the strength and shock resistance required for an application where the outer rings are not supported by a housing. They are sealed, Conrad type bearings with spherical OD's for minimizing the effects of misalignment. They have bores dimensioned to receive standard machine bolts. See Figure 13.

Adapter bearings have extended inner rings with eccentric locking collars for easy mounting on standard commercial grade size shafts. The collar is rotated and locked in place with a set screw for permanent bearing mounting.

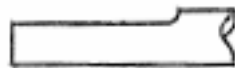
Figure 10

Specialty Ball Bearings

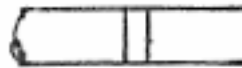


Integral Shaft  
Ball Bearing

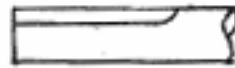
Specialty Ends



Flat



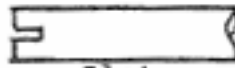
Hole



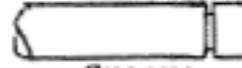
Keyway



Notch



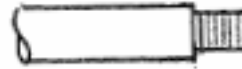
Slot



Groove



\* Taper



Thread

Applications

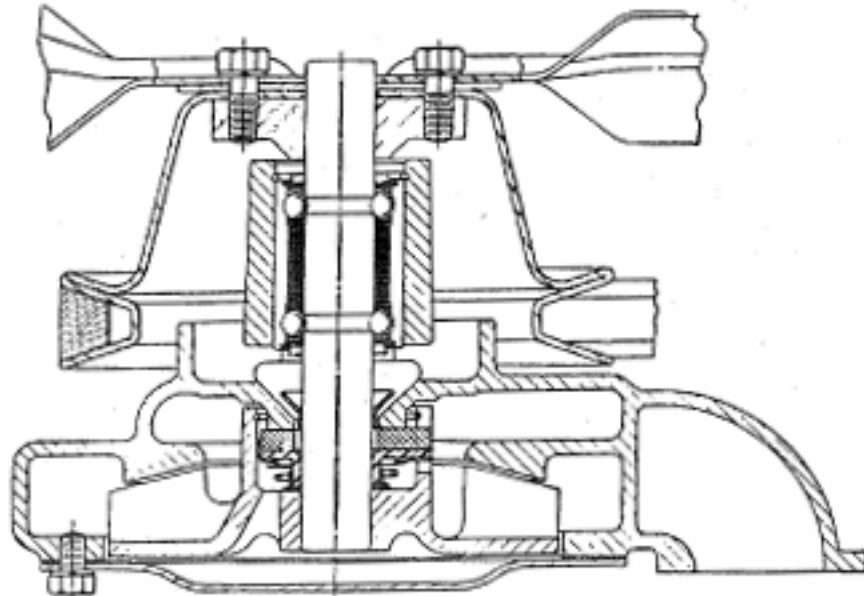
Bench Grinders  
Centrifugal Pumps  
Fan & Waterpumps

Fans & Blowers  
Lawn Tractors  
Polishing Heads

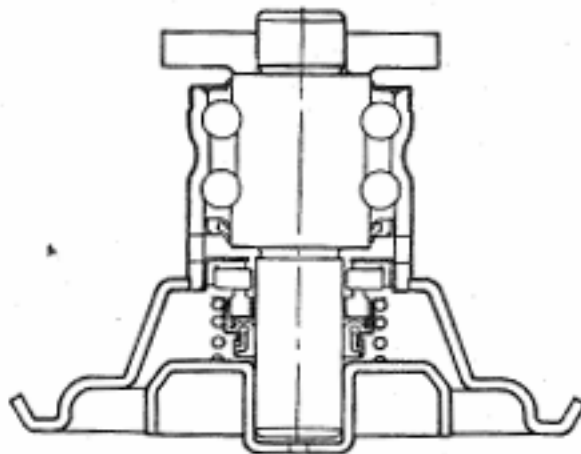
Table Saws  
Washing Machines  
Wheel Mounts

Figure 11

Specialty Ball Bearings



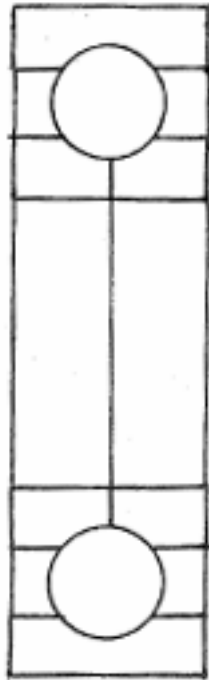
Traditional Automobile Waterpump  
With Integral Shaft Ball Bearing



Later Version Waterpump  
With Stepped Shaft Bearing

Figure 12

Specialty Ball Bearings



Split Inner Ring Ball Bearing

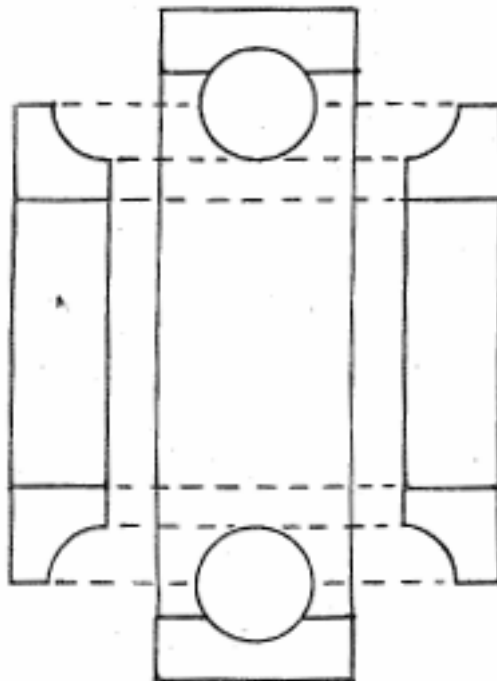
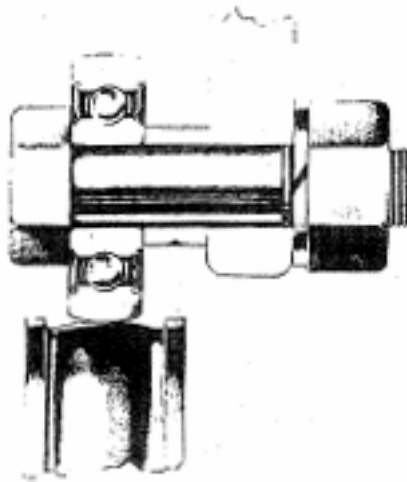
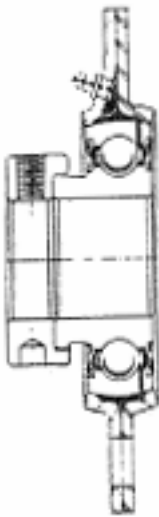


Figure 13

Specialty Ball Bearings



Cam Follower Bearing



Adapter Bearing With Flange

They are designed for installations where loads and speeds are moderate and concentricity requirements not too critical. The bearings are lubed and sealed for life and have spherical outer rings for misalignment compensation. Two piece flange mounting units are available which clamp onto the outer ring. See Figure 13.

Disc harrow agriculture bearings are sealed, Conrad type bearings with extra wide inner rings. They have bores which fit standard machine bolts for economical mounting. There are a number of special seals and shields available for extreme duty use. See Figure 14.

Hay rake tine bearings are standard Conrad type bearings with inch dimension bores to fit standard machine bolts for easy mounting to agricultural equipment. Special mounting studs can be shipped with the bearings. Heavy duty seals are available. See Figure 14.

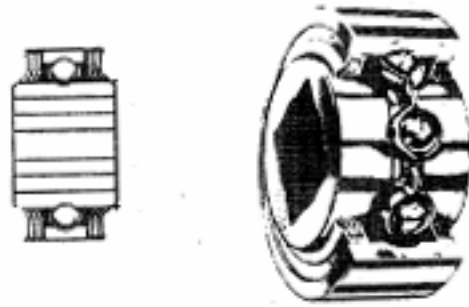
Conveyor bearings have heavy duty seals because of the contaminated conditions inside idler rolls where they are used. The bearings are lubed for life to avoid costly maintenance procedures. The bore fits standard round or hex shafts. The bearings can be supplied with special stub shafts with crowned teeth that can fit the hex bore of the bearing to compensate for misalignment. See Figure 14.

A very high volume specialty ball bearing product now being used in the automotive industry is the integral wheel bearing unit. It is comprised of two rows of balls riding directly on pathways on the spindle and in the hub. The units are assembled, grease lubricated, sealed, and tested on automatic equipment. It fits the modular assembly concept well because it comes as a sealed-for-life package that bolts directly to the vehicle and the wheels bolt directly to it. There is a design made for both drive and non-drive wheels. They are used extensively on front drive automobiles. See Figure 15.

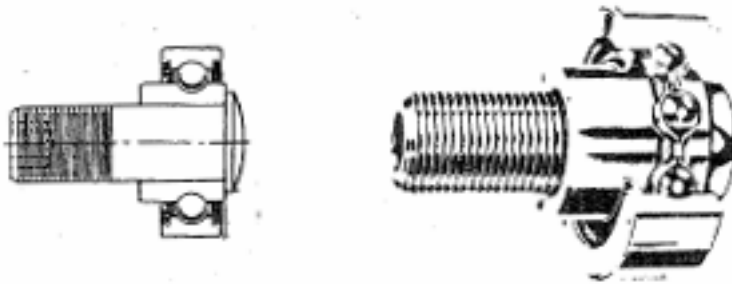
**Internal Clearance:** Internal clearance is the looseness that radial ball bearings are built to in order to operate satisfactorily. One measure of internal clearance is a term called radial play. Radial play is defined as the total travel of one ring with respect to the other in the radial direction. Another measure of internal clearance is called end play. End play is defined as the total travel of one ring with respect to the other in the axial direction. Radial play for radial ball bearings ranges from .0001" - .0005" for a small bearing and from .0008" - .0024" for a large bearing.

Figure 14

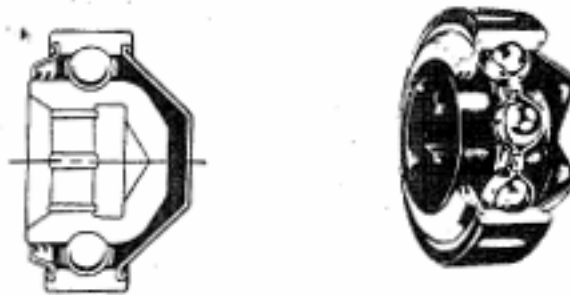
Specialty Ball Bearings



Disc Harrow Bearing



Hay Rake Tine Bar Bearing

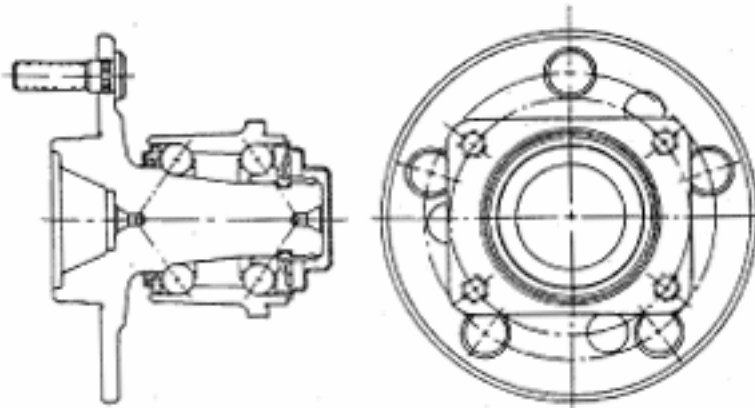


Conveyor Bearing

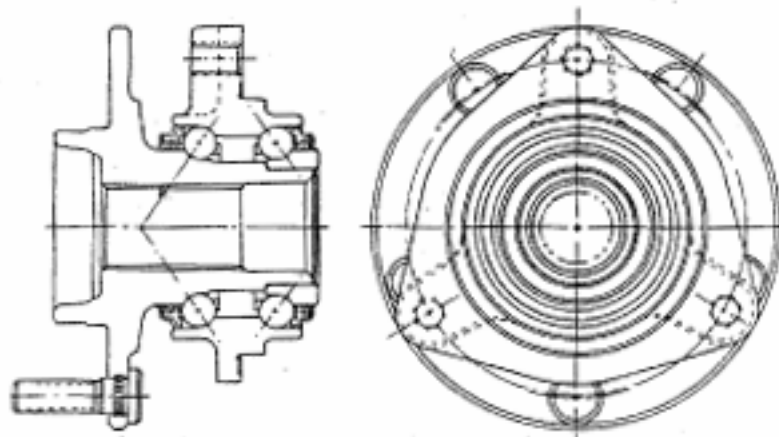


Figure 15

Specialty Ball Bearings



Integral Non-Drive Wheel Bearing



Integral Drive Wheel Bearing

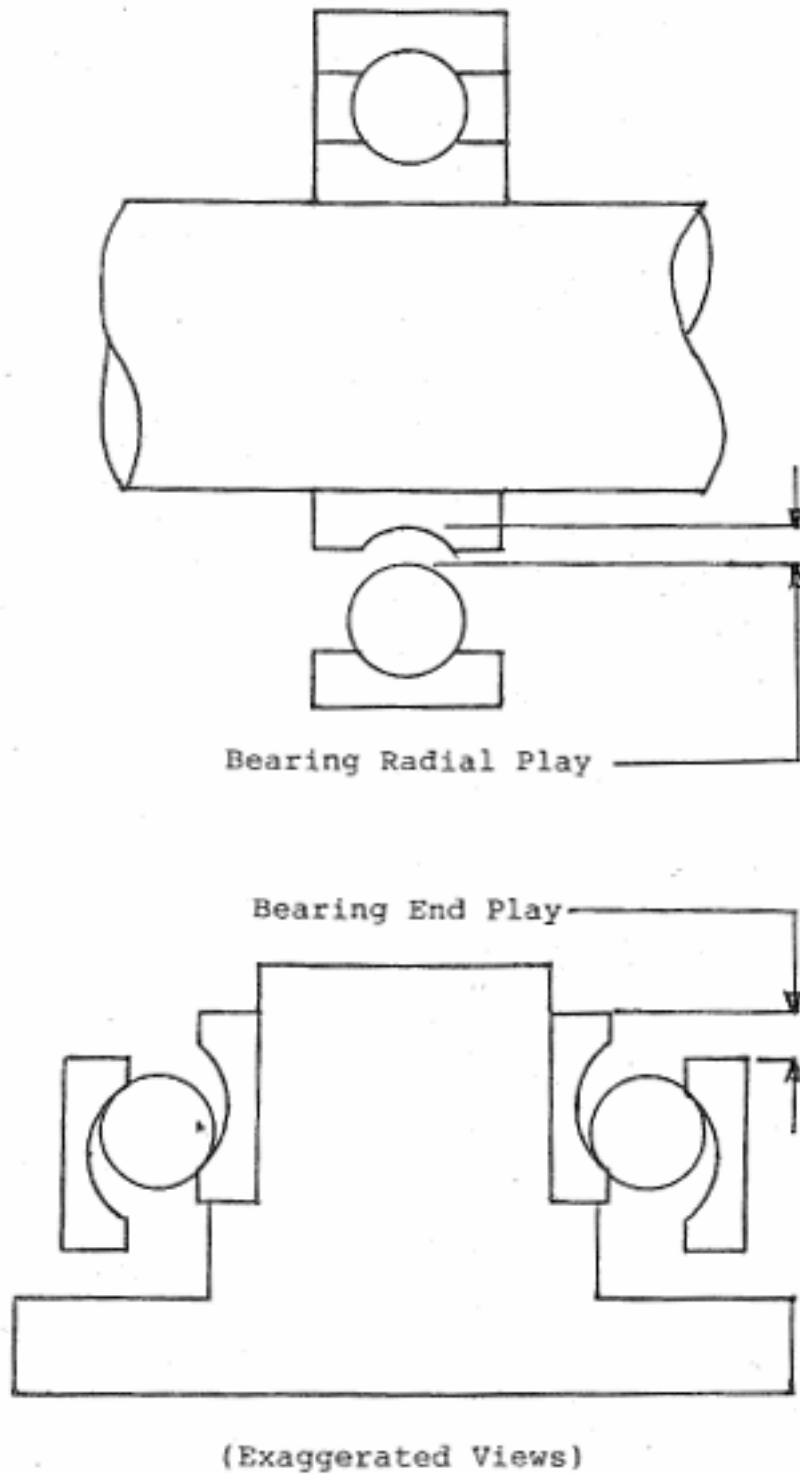
Corresponding end plays are .0020" - .0040" for the small bearing and .0145" - .0220" for a large bearing. Approximately 80% of the radial play of a bearing is lost when either the inner ring or the outer ring is press fitted onto its mounting surface. Sometimes bearings have to be built to special radial plays to compensate for non-standard press fits, non-ferrous shaft or housing materials, non-standard shaft or housing wall thicknesses, or unusual operating conditions or temperatures. See Figure 16.

**Shaft and Housing Fits:** Under normal load and service conditions, the rotating ring has an interference fit with its mating member and the non-rotating ring has a close push fit with its mating member. This arrangement prevents the rotating ring from spinning on its seat while the non-rotating ring is allowed to move relative to its seat. Allowing one ring to move on its seat prevents unwanted thrust loads from building up due to differential thermal expansion between the shaft and the housing. Also, installation of bearings is greatly facilitated when one of its rings is a push fit. Changes to standard fitting practices are made under the following conditions: unusual loading, abnormal operation temperatures, non-ferrous materials, and non-standard shaft and housing wall thicknesses. Normal shaft press fits range from .0005" tight to .0001" loose for a small bearing and from .0017" tight to .0002" loose for a large bearing. Normal housing loose fits range from .0001" tight to .0008" loose for a small bearing and from .0003" tight to .0027" loose for a large bearing.

**Lubrication:** High grade mineral oils are the best lubricants for ball bearings. Commonly used means for delivering oil to bearings include jet, bath, mist, and wick feed. The best overall system is oil jet combined with a recirculating system. This method directs a pressurized stream of oil at the bearing load zone. The oil is then drained back to a sump where it is filtered, cooled, and returned. This system is good for a wide variety of loads and speeds. The oil bath method is commonly used in gear boxes. The housing is filled with oil until it just touches the lowest rotating component. The oil is then splashed throughout the gearbox. Mist systems use pressurized air to atomize oil. The mixture is then sprayed on the bearing where it lubricates and cools. Air-oil mist systems are used primarily for high speed applications. Wick systems use an absorbent material to store oil and slowly deliver it to a bearing in a controlled manner. This system is used in electric motors. The simplest method of lubricating bearings is by using grease. A carefully measured amount of grease is evenly distributed throughout the bearing where it is contained by seals or shields. This configuration can run for the life of the bearing.

Figure 16

Bearing Internal Clearance



The following is a list of greases:

- 1) Mineral oil greases are used for general purpose operation at a temperature range of -30 degrees to +300 degrees F.
- 2) Diester oil greases are designed for low temperature operation down to -65 degrees F.
- 3) Ester based greases are products that operate over a range of -100 degrees to +350 degrees F.
- 4) Silicone oil greases have operating temperature ranges of -100 degrees to +450 degrees F, but lack good load carrying capability.
- 5) Fluorosilicone oil greases have all the desirable characteristics of silicone oil greases plus good load carrying capability.
- 6) Perfluorinated oil greases are non-flammable, have good load carrying capacity and can operate at temperatures up to +550 degrees F.

Grease consistency is important. Greases that are too soft will cause excessive churning losses in a bearing while greases that are too hard will not lubricate properly. The above greases can be obtained at various consistencies. Figure 17 is a plot of recommended oil viscosity vs. operating temperature for a 30 mm bore bearing running at 2000 rpm. It can be seen from the graph that very high viscosity oils are needed by bearings that run at high temperatures.

Application: The application of ball bearings to machine design involves more than load and speed calculations. It also involves how the bearing is to be mounted and how to prevent unwanted thrust loads from differential thermal expansion between the shaft and the housing. Figures 18, 19, 20, 21, and 22 contain drawings and the explanations of the functions of ball bearings in machine parts.

Figure 17

Bearing Lubrication

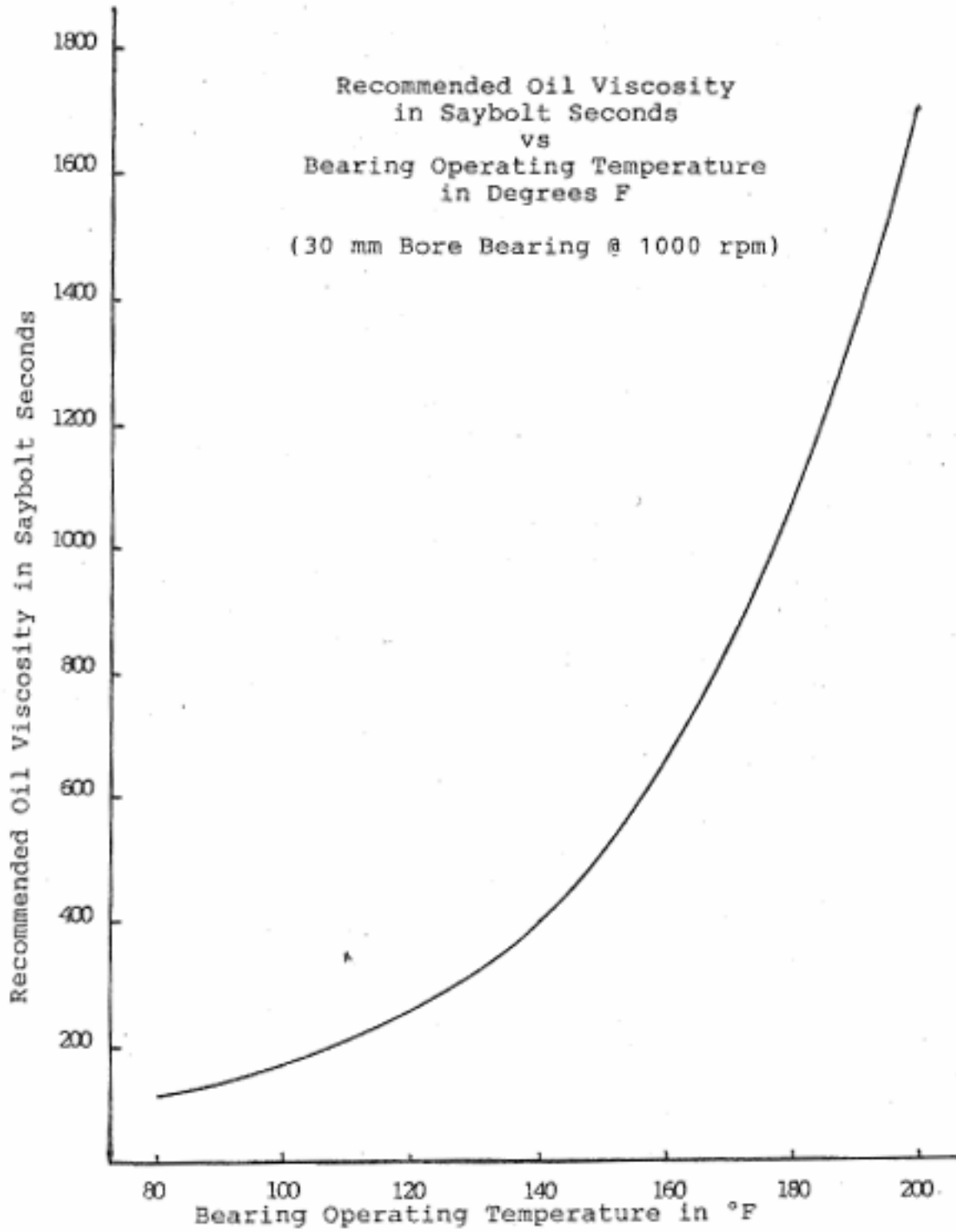
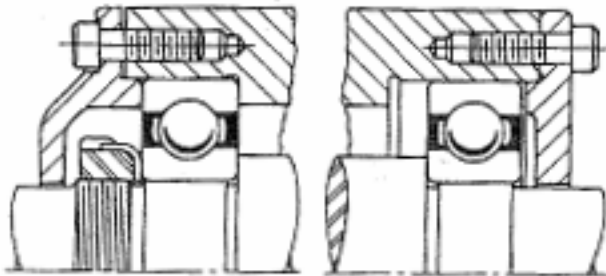
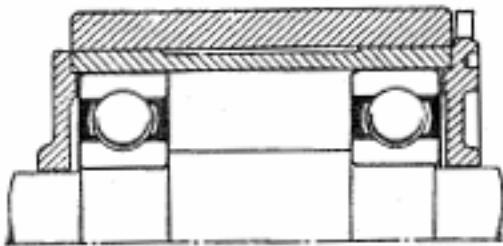


Figure 18

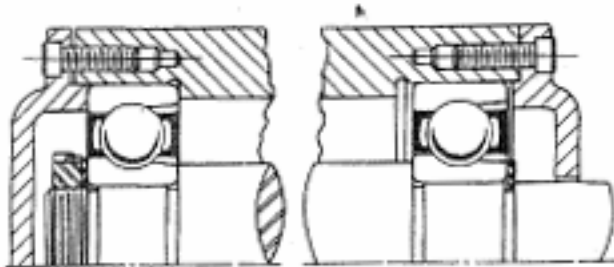
Radial Ball Bearing Application



The bearing on the left is clamped to the housing and the shaft. The bearing on the right is free to accommodate shaft thermal expansion and tolerance build-up.



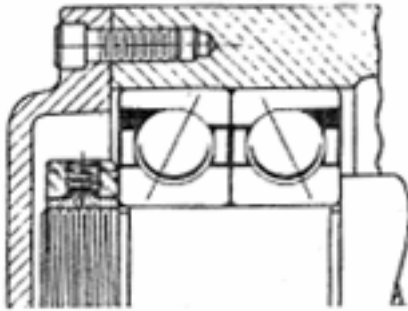
Both bearings can be made to float in the housing if shaft end play is not critical.



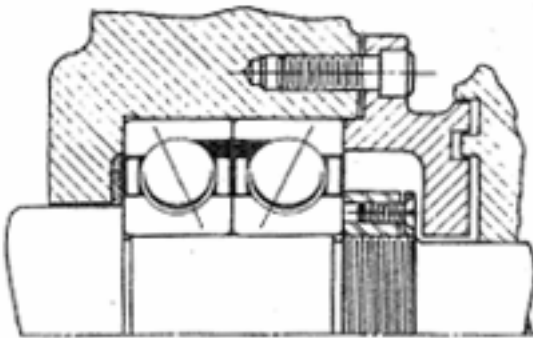
When thrust loads are low, loading groove bearings can be used to take heavy radial loads.

Figure 19

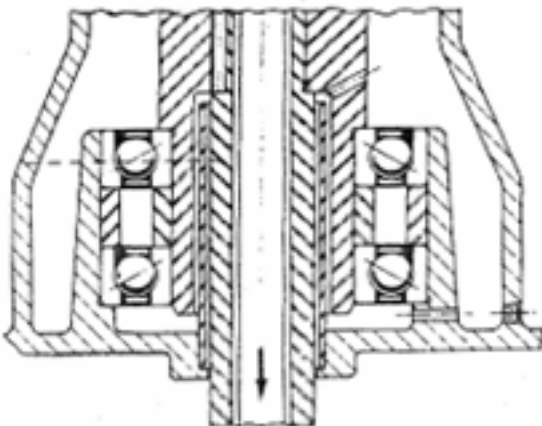
Angular Ball Bearing Application



Maximum resistance to high moment loading is obtained by using two angular contact ball bearings mounted back-to-back.



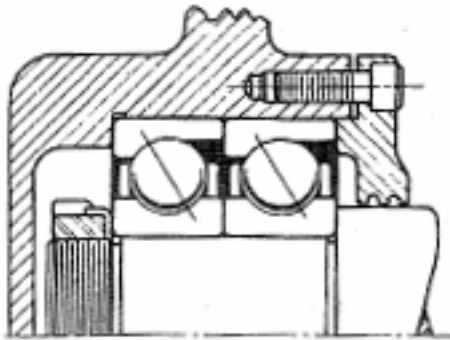
Compliance to high shaft misalignment is accomodated by using two angular contact ball bearings mounted face-to-face.



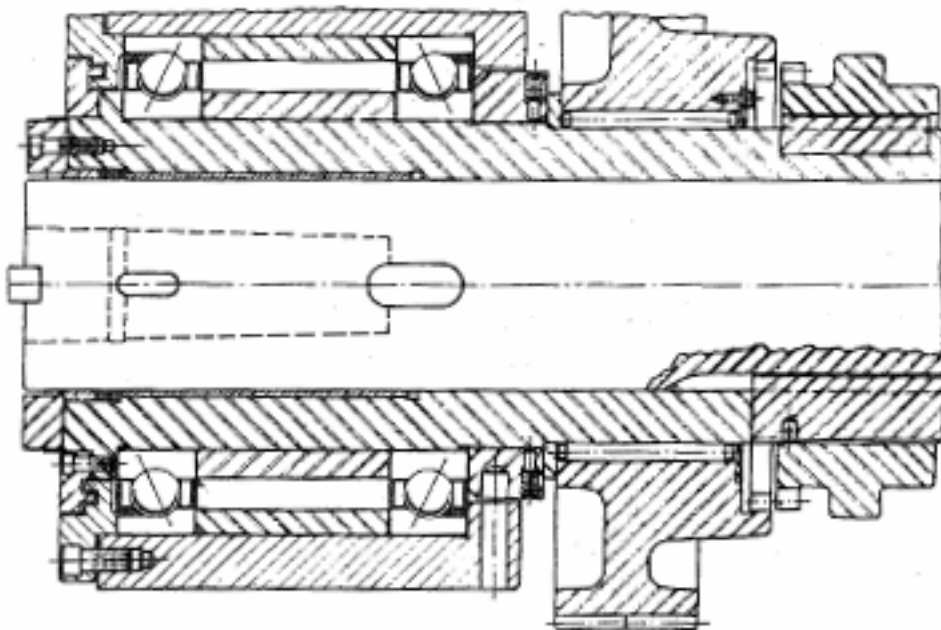
Support of high one-direction thrust loading is accomplished by using two angular contact ball bearings mounted in tandem. The thrust is downward on the shaft.

Figure 20

Angular Contact Ball Bearing Application



Very high one-direction thrust loads can be taken by tandem mounted angular contact ball bearings mounted face-to-back.

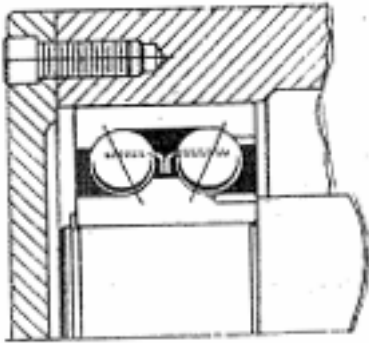


Angular contact ball bearings mounted apart and separated by spacer rings can take even more moment loading than back-to-back mounting.

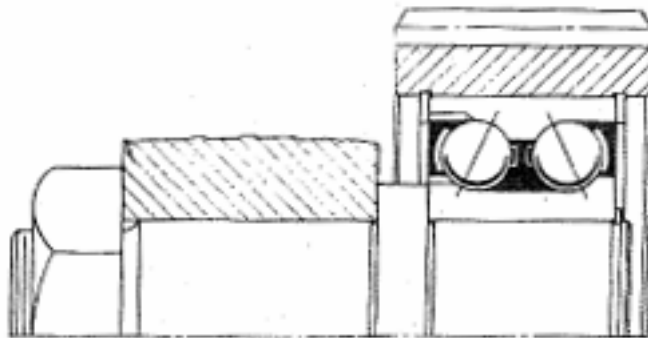


Figure 21

Double Row Ball Bearing Application



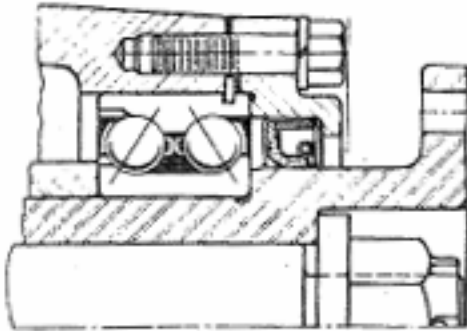
Double row ball bearings with contact angles internally convergent can take misalignment and heavy radial loads.



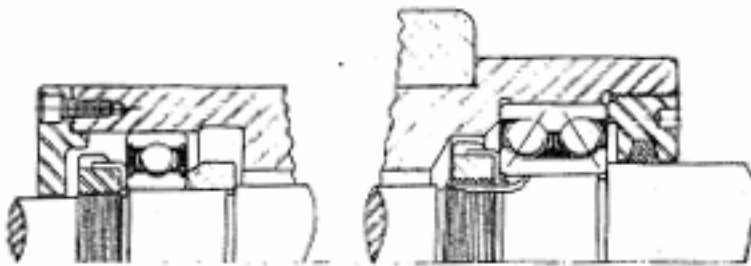
Double row ball bearings with contact angles internally divergent can take heavy overturning moment loading.

Figure 22

Double Row Ball Bearing Application



The housing can be thru-bored when a snap ring is used on the bearing outer ring.



A double row ball bearing is used when reversing thrust loads are present in an application.